

GalvinLab™ CP-BS Lab Set 1-Way Bench Mounted Deionized Unit Max 400kPa

Specification Data Sheet



Features

- Vandal resistant fittings are standard which are suitable for both educational and research labs
- Polyester powder coating provides better chemical UV light and heat resistance than chrome plated
- Quality controlled. Every valve is tested
- Colour coded handles - Chemical symbols according to EN 13792 for convenient indication of media
- Tube nozzles or aerator are available on all water units.
- Replaceable top assemblies are supplied for easy maintenance
- Specialised top assemblies give precise flow and regulation
- Exchangeable nozzles for flexible choice of outlet connection
- High quality chrome finish for easy cleaning and hygiene maintenance
- Australian Made; therefore, spare parts and support are available locally, reducing costs of down time on maintenance

To Specify

Australian Made AS/NZS 3718 approved, Galvin Specialised GalvinLab™ range of laboratory tapware is supplied standard with tube nozzle, Stirling DIN 13792 approved easy use handle and button, G 1/2" BSP inlet all finished in chrome plate.

Code:

TLDIMPC - GalvinLab™ Lab Set 1-Way Bench Mounted Deionized Unit Max 400kPa



A family
owned
Australian
business



Typical Dimensions

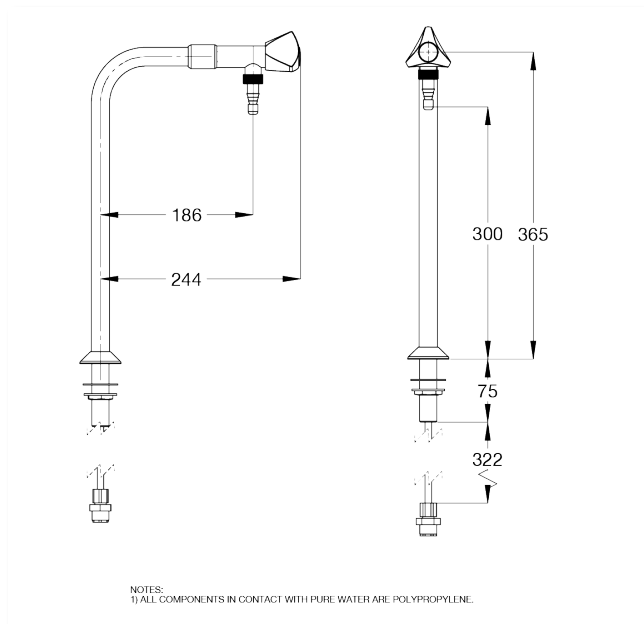

Mounting Information

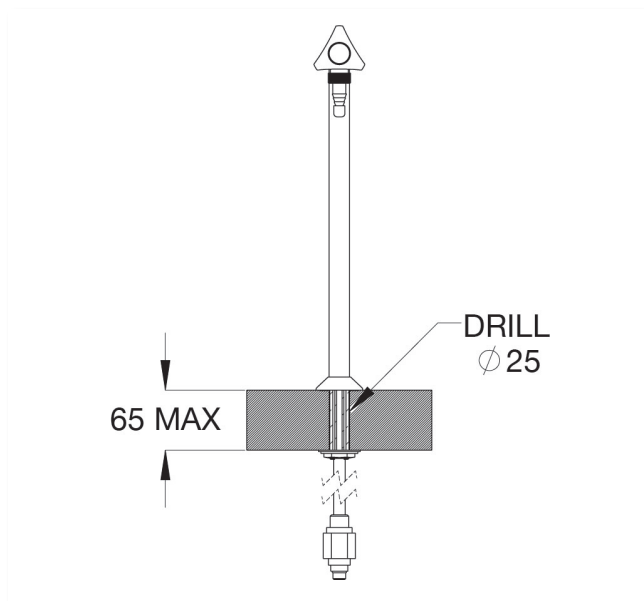

Technical Specifications

Main materials:

Tap body: Polypropylene (PP) and Polyethylene (PE)

Headwork: Ceramic

Handle: Brass with media indication according to EN13792

Handle Colour: With accordance to DIN EN 13792

Body Colour: Chrome

Inlet: G 1/2" BSP

Outlet: Tube Nozzle

Materials with Media Contact

Tap body: PP and PE

Internal piping: Polyethylene (PE)

Sealing: Ceramic

Nozzle: PP

Maintenance & Cleaning

Galvin Specialised products should be cleaned with a soft damp cloth using only mild liquid detergent or soap and water. Do not use cleaning agents containing a corrosive acid, scouring agent or solvents. Do not use cream cleaners, as they are abrasive. Use of unsuitable cleaning agents may damage the surface. Any damage caused in this way will not be covered by warranty.

Regular maintenance should be carried out in accordance with the installation and troubleshooting guides provided with the product, relevant Australian Standards, local authorities and state codes.

As part of maintaining a safe and reliable plumbing system, we recommend tapware and valves are operated on at least a daily basis.

Warranty

Galvin Engineering products are covered under our Manufacturer's Warranty at www.galvinengineering.com.au. Galvin Engineering products must be installed in accordance with the installation instructions and in accordance with AS3500 and the PCA, relevant Australian Standards and local authorities applicable to product being installed. Water and electrical supply conditions must also comply to the applicable national and/or state standards, failing to comply with these provisions may void the product warranty and affect performance of the product.

Whilst all reasonable care has been taken in compiling the information in this document, the designs, dimensions and products shown are indicative only and should not be relied upon without our prior approval. Due to our policy of continuous development, we reserve the right to alter any details of specifications or products without notice. All information, drawings, technical specifications and product designs remains the property of Galvin Engineering Pty Ltd.

Within Australia: **1300 514 074** Outside Australia: P: +61 (0)8 9338 2344

F: +61 (0)8 9338 2340

sales@galvinengineering.com.au

www.galvinengineering.com.au

ABN: 78 008 719 382

A business unit of

GalvinEngineering
the mark of reliability



PERTH | SYDNEY | MELBOURNE | BRISBANE | ADELAIDE | UNITED STATES OF AMERICA | UNITED KINGDOM | NEW ZEALAND